

WALL MOUNT FAUCET WM-100-55

FEATURES

- ✓ Heavy duty construction
- ✓ 20" Riser brass pipe
- ✓ 55" flexible stainless steel hose with Santoprene inner pipe
- ✓ Includes check valve to prevent cross-flow
- ✓ Spray valve conforms to ANSI/ASTM F2324-03
- ✓ Installation kit included
- ✓ Spray Valve
- ✓ Wall bracket

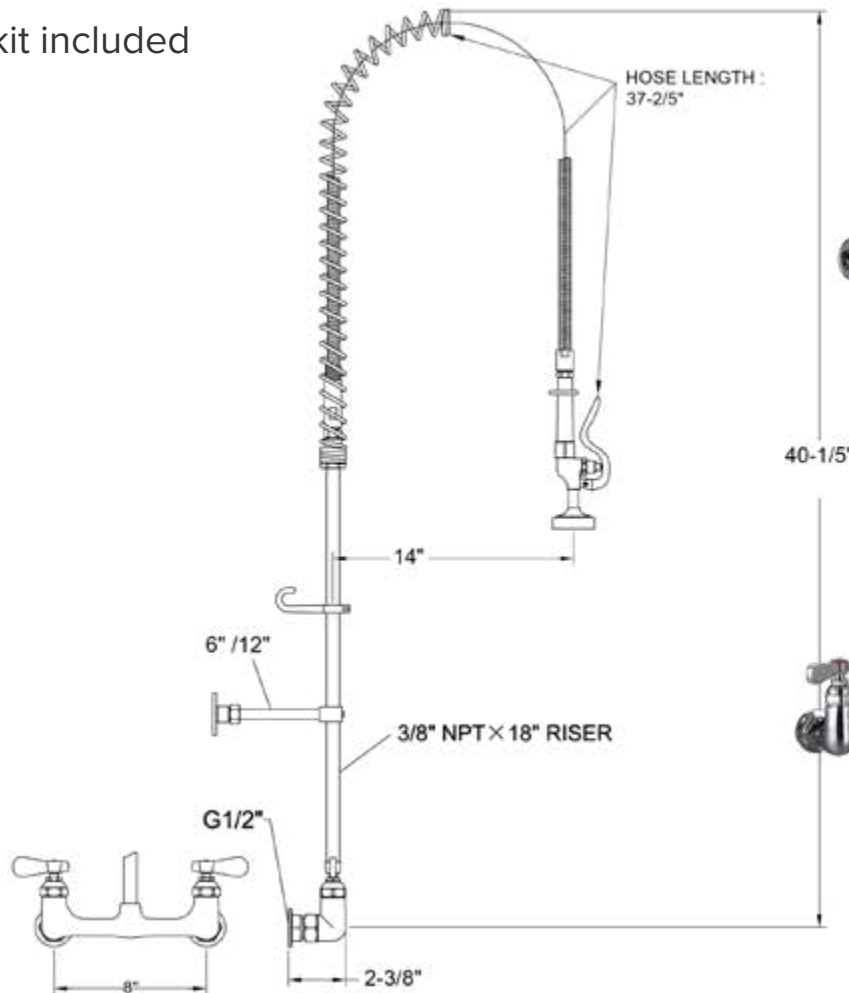

ASSEMBLY/SUPPORT



MORE PRODUCTS

